

vapor pressures calculated from equation (3) are listed, assuming that the molecular species in the vapor phase is either pure B_2O_3 or pure B_4O_6 . The data are also plotted in Fig. 1 as B_2O_3 .

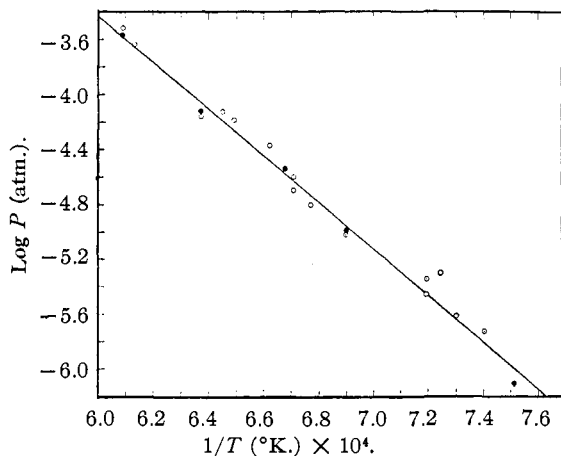

Fig. 1.—Vapor pressure of B_2O_3 .

The slope of the $\log p$ vs. $1/T$ plot shown in the graph, yields a value of 77.6 kcal. as the mean

value of the heat of evaporation of boric oxide over the temperature range 1330 to 1640°K.

Least squares fitting of the data to the Clausius-Clapeyron equation for the B_2O_3 molecule yields the expression

$$\log p \text{ (atm.)} = -(77600/4.575T) + 6.742 \quad (4)$$

and for the B_4O_6 molecule, the expression

$$\log p \text{ (atm.)} = -(77600/4.575T) + 6.591 \quad (5)$$

Summary

The vapor pressure of boric oxide has been determined by measuring the rate of effusion through an orifice in a platinum Knudsen cell.

Experiments show that boric oxide is not decomposed into non-condensable products in the temperature range 1300 to 1650°K.

Since it is not known whether the molecular species in the vapor is B_2O_3 or B_4O_6 , the vapor pressures are computed from the effusion data assuming the possibility of either structure.

The heat of evaporation as determined by application of the Clausius-Clapeyron equation is 77.6 kcal.

RECEIVED NOVEMBER 25, 1949

[CONTRIBUTION FROM THE ALUMINUM RESEARCH LABORATORIES]

Spectroscopic Investigation of the Reaction between Aluminum and Aluminum Chloride

BY L. M. FOSTER, ALLEN S. RUSSELL AND C. NORMAN COCHRAN

Several proposals to produce or purify aluminum involve the "catalytic distillation" of the material from a charge of impure metal or aluminum bearing alloy in the presence of an aluminum halide. In an early process described by Willmore,¹ the aluminum bearing material was admixed or briquetted with aluminum fluoride and the mass was heated in vacuum, or an inert gas, to the vicinity of 1000° where appreciable distillation of pure aluminum was observed. The simultaneous sublimation of aluminum fluoride suggested that the aluminum and the halide had reacted at the high temperature to form a volatile lower fluoride of aluminum which on cooling disproportionated to metallic aluminum and aluminum trifluoride. Gross² proposed that the aluminum halide be volatilized in a separate boiler and passed over a bed of aluminum bearing material.

Fairly convincing evidence had been obtained in these Laboratories and elsewhere that the lower halide involved was the monohalide, AlX. An accurate determination of the composition of

the sublimed products obtained by heating an intimate mixture of aluminum fluoride and metallic aluminum was made by Klemm and Voss.³ Repeated sublimation gave a product whose over-all composition closely approached that corresponding to AlF.

Perhaps the most convincing proof of the existence of aluminum monohalides in these reactions is the character of the absorption spectra of the reaction vapors. Rochester⁴ had determined the absorption spectrum of AlF from thermal dissociation of aluminum fluoride, heated in a carbon resistance furnace to 1300-1700°. In 1940 Anderson,⁵ in these Laboratories, observed the same partially developed spectrum of AlF from the heated vapors of briquetted aluminum, aluminum fluoride, magnesium fluoride and graphite, at about 1000°.

The spectrum of AlCl had been observed by excitation of aluminum chloride vapors in an electric discharge.⁶ Analysis of the spectrum was

(3) W. Klemm and E. Voss, *Z. anorg. allgem. Chem.*, **251**, 233 (1943).

(4) G. D. Rochester, *Phys. Rev.*, **56**, 305 (1939).

(5) S. Anderson, unpublished work.

(6) W. Jevons, *Proc. Roy. Soc. (London)*, **A106**, 174 (1924).

(1) C. B. Willmore, U. S. Patent 2,184,705 (1939).

(2) P. Gross, U. S. Patents 2,470,305 and 2,470,306 (1949) (see also Australian Patent Application 10,766 (1947) of the International Alloys Ltd.)

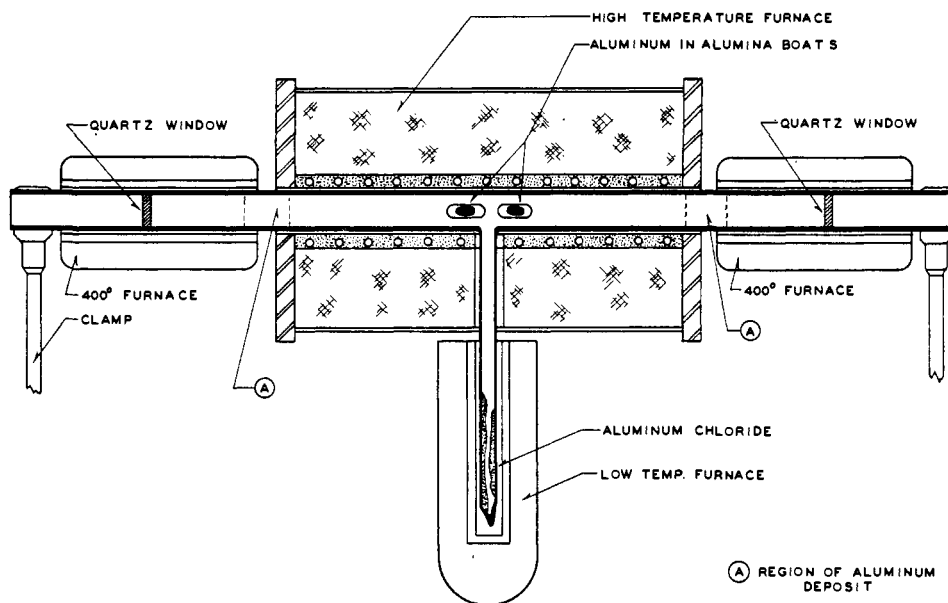

Fig. 1.—Spectroscopic absorption tube.

made by five separate groups about 1934.⁷⁻¹²

It was the aim of the present work to investigate the mechanism of the reaction of aluminum chloride with aluminum by spectroscopic means, and to compare the experimental findings with theoretical calculations.

Experimental

The general layout of the absorption tube and auxiliary equipment is shown in Fig. 1. The absorption tube proper was constructed from 20-mm. I. D. Vycor or quartz tubing. A clear quartz window, 2-mm. thick, was sealed into each end at a position about 4" from the end of the tube. This made it possible to heat the windows with small sleeve heaters and still permit rigid clamping of the tube at either end. The aluminum chloride was contained in a side arm which could be heated with a removable sleeve heater to provide the aluminum chloride pressure. During the course of the investigation several different absorption tubes were used which differed from the one shown primarily in the location and method of heating of the side arm. The sleeve heater around each window was kept at 300–400° to prevent the condensation of aluminum chloride in these regions.

In the experiments where aluminum was used, the metal, in the form of two or more 0.1-g. pieces, was supported on small, flat, fused-alumina boats which did not obstruct the light beam appreciably.

In one experiment, an all-Pyrex glass sickle-type pressure gage was attached to the absorption tube by means of a quartz-Pyrex graded seal. In all other experiments the temperature of the side arm was measured, and the vapor pressure was read from the aluminum chloride equilibrium vapor pressure curve of Smits and Meijering.¹³

The aluminum chloride was either Eimer and Amend C. P. grade or was made immediately prior to use by treating dry hydrogen chloride gas with pure aluminum.

(7) F. H. Crawford and C. F. Ffolliott, *Phys. Rev.*, **44**, 953 (1933).

(8) B. N. Bhaduri and A. Fowler, *Proc. Roy. Soc. (London)*, **A145**, 321 (1934).

(9) P. C. Mahanti, *Z. Physik*, **88**, 550 (1934).

(10) W. Holst, *ibid.*, **93**, 55 (1934).

(11) E. Miescher, *Helv. Phys. Acta*, **7**, 462 (1934).

(12) Miescher, *ibid.*, **8**, 279 (1935).

(13) A. Smits and J. L. Meijering, *Z. physik. Chem.*, **B41**, 98 (1938).

In all cases the material was resublimed twice before using, and finally condensed in vacuum in the side arm of the absorption tube.

All exposures were made on Eastman type S. A.-1 (Spectrum Analysis) plates with a Gaertner L254 quartz-prism spectrograph having a dispersion of about 3.2 Å. per mm. in the vicinity of 2600 Å. The light source was the continuum of a hydrogen lamp focused on the slit with a quartz condensing lens. The most satisfactory spectra were obtained with exposure times of one minute. In experiments in which both aluminum and aluminum chloride were present in the tube at high temperatures, the windows became fogged, after short periods of operation, from reaction of monochloride with the quartz.

Two types of experiments are reported here. In the first, the absorption spectra of aluminum chloride were observed as a function of temperature at constant aluminum chloride pressure, and in the second, metallic aluminum was added and both temperature and pressure were varied in separate experiments.

Plate A of Fig. 2 shows the spectra of the products obtained by heating aluminum trichloride to the vicinity of 1000°. In this experiment the aluminum chloride pressure was maintained constant at about one atmosphere, while the temperature was increased slowly from 654–1080°. The lowest temperature at which an absorption band was observed was 936°.

The band structure in the neighborhood of 2600 Å., though faint in the reproduction, was distinct on the original plate. About seven bands were visible to the eye. The heads of the most prominent were at 2614.5, 2617.0 and 2620.0 Å. These correspond well with the bands reported at 2614.44, 2616.97 and 2619.98 Å., by Bhaduri and Fowler⁸ from emission spectra of AlCl₃, and this is taken as proof of the dissociation of AlCl₃ to AlCl by thermal excitation in the temperature region investigated

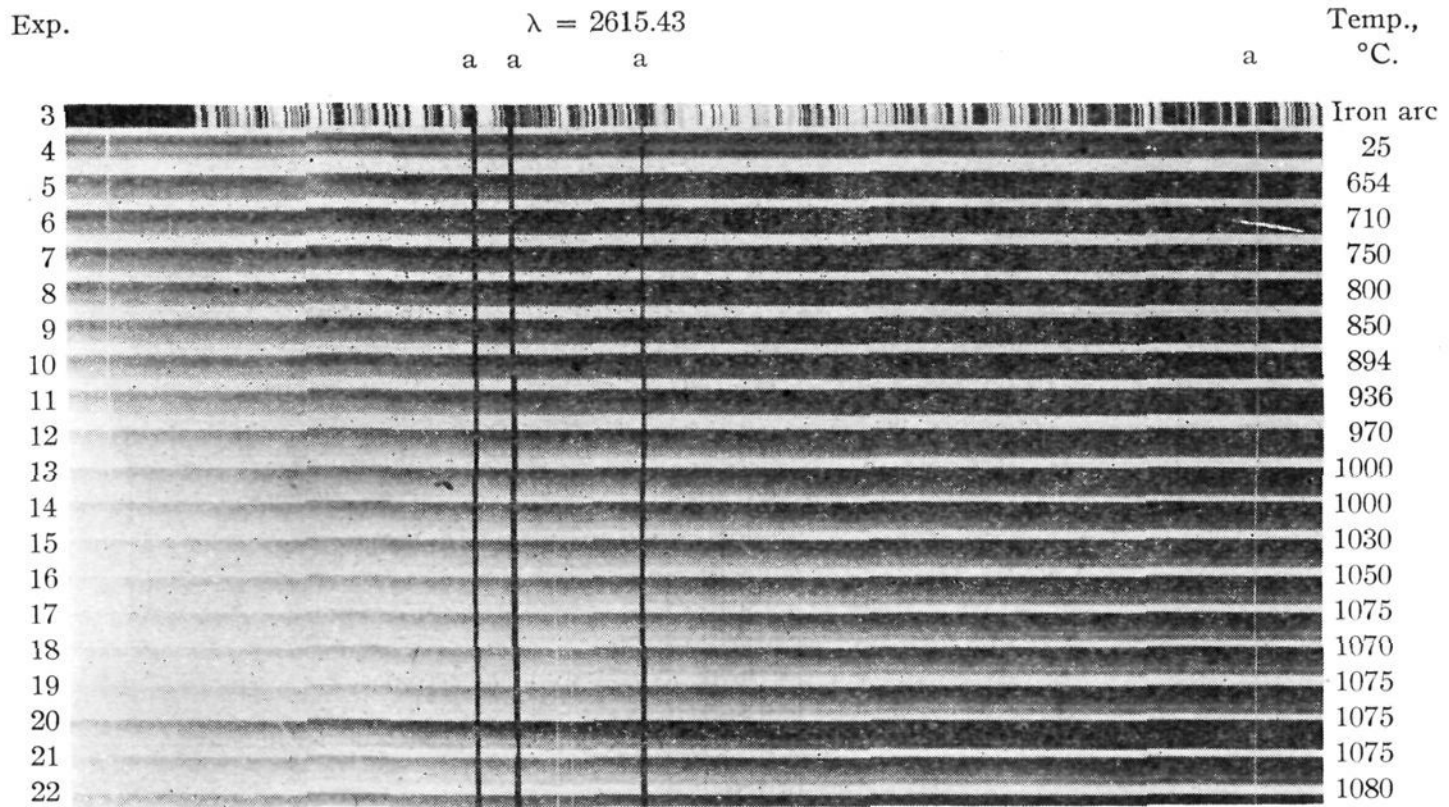

Plate A.—Aluminum absent, AlCl_3 press. 0.92 atm.; a, reference lines.

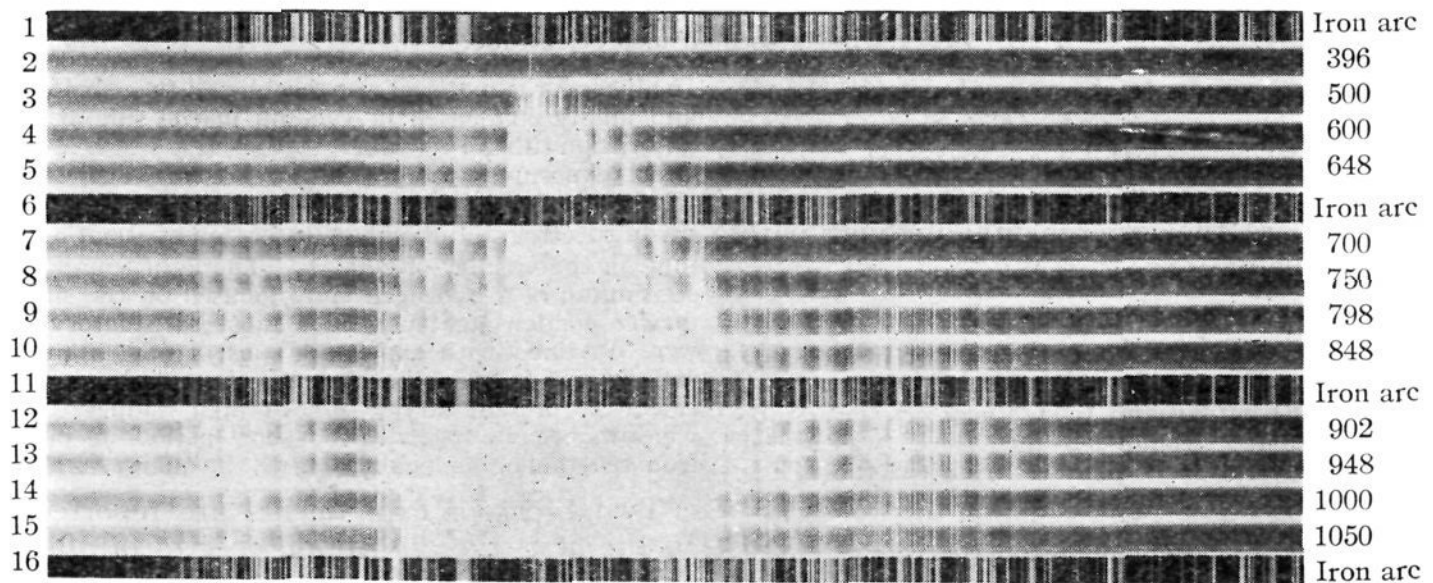

Plate B.—Aluminum present, AlCl_3 press. 0.12 atm.

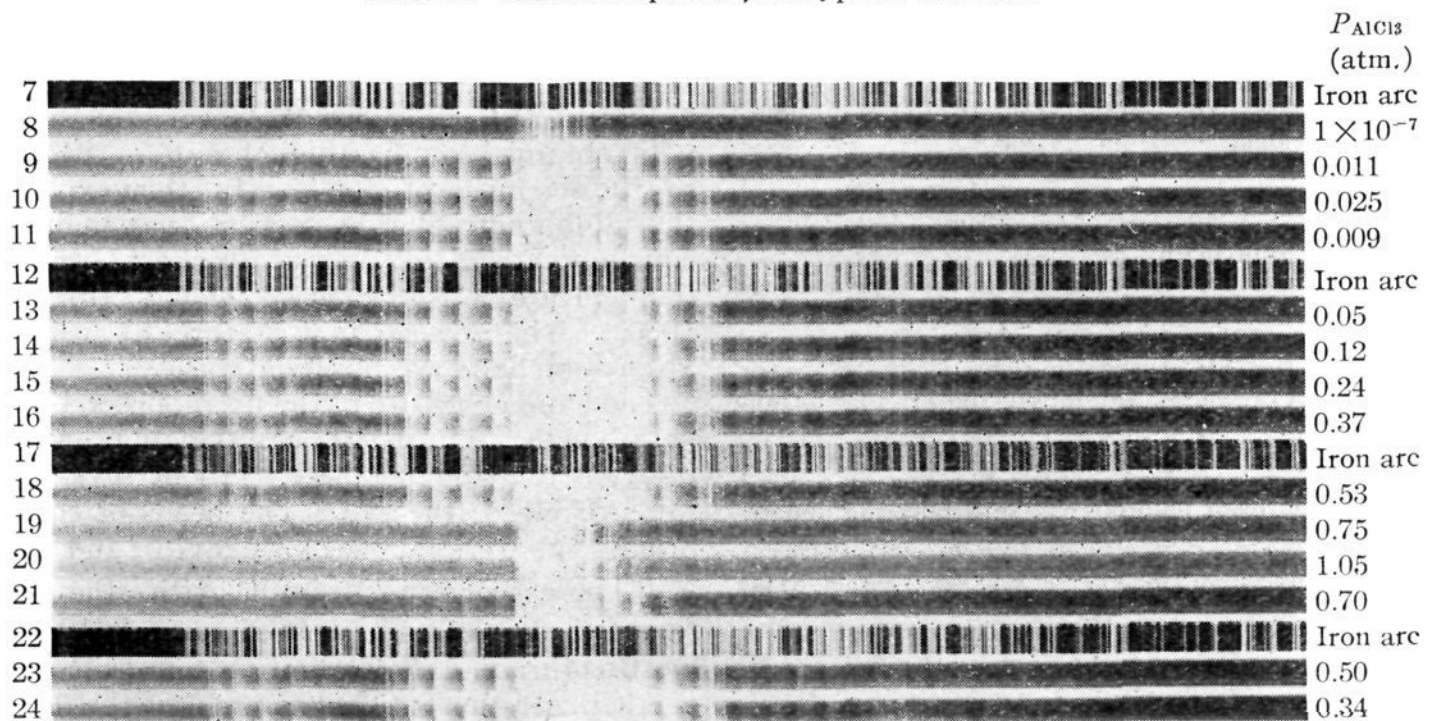

Plate C.—Aluminum present, temp., 700° .

Fig. 2.—Absorption spectra of AlCl_3 .

There was a gradual increase in AlCl concentration with temperature above 936°, as evidenced by the increase in number and intensity of AlCl band heads.

Plates B and C of Fig. 2 show the spectra of the gaseous products obtained by heating aluminum trichloride in the presence of metallic aluminum to various temperatures at constant pressure (Plate B), and various pressures at constant temperature (Plate C). The very striking increase in AlCl concentration resulting from the addition of metallic aluminum is apparent by comparing Plate A with Plate B. The AlCl concentration was approximately the same in exposure 2, Plate B, at 396° and 0.12 atmosphere pressure, in the presence of aluminum as in exposure 21, Plate A at 1075° and one atmosphere pressure, with aluminum absent. The effect was even more striking at higher temperatures.

The AlCl concentration was seen to increase steadily with temperature in Plate B up to exposure 12. In exposures 13, 14 and 15, the concentration appeared to decrease in spite of further increase in temperature. On breaking open the tube after completion of the experiment, it was found that all of the aluminum had distilled from the boats to the colder parts of the tube, which undoubtedly accounted for the decrease in concentration of monochloride in the last exposures. In Plate C, the AlCl concentration was seen to increase with pressure to about one-third atmosphere, but at higher pressures did not follow the expected course. The concentration decreased with further increase in pressure beyond 0.37 atmosphere, and showed no consistent variation thereafter. No completely satisfactory explanation has been found for this anomalous behavior. It can possibly be attributed to competitive reactions at high pressures or to the diffusion of the gaseous products out of the hot zone faster than they could be replaced because of the limited surface of aluminum exposed. An experiment, not discussed here, wherein the pressure was measured with a sickle-type gage, did not show this anomaly, and it is possible that insufficient time was allowed for pressure equilibrium in the other experiments.¹⁴

In the detailed analysis to follow, those exposures were not considered which showed the anomalous pressure behavior, or were not satisfactory for other reasons.

The method employed to determine the AlCl concentration experimentally was as follows: The theoretical concentrations, as derived in the appendix, were assigned to the exposures of Plate A (Fig. 2), where the monochloride resulted from the thermal dissociation of aluminum trichloride, thus

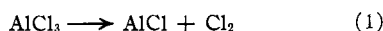

By comparing the extent of absorption in the exposures of this plate, as determined by densitom-

eter measurements, with the exposures of Plates B and C, the AlCl concentrations were obtained for the latter by application of Beer's law. Since the range of band intensities on Plates B and C greatly exceeded the sensitive range of the spectroscopic plate it was not possible to follow the intensity change of bands near the origin throughout the entire series of exposures. Consequently it was necessary to assume that the relative intensity of the bands in any one exposure did not change significantly with temperature. This permitted the use of outlying bands whose intensities could be accurately measured. The concentrations of Plates B and C were then compared with the theoretical concentrations for the reaction

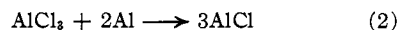

as calculated in the appendix. Beer's law states that

$$I/I_0 = e^{-k^*c} \quad (3)$$

where I/I_0 is the fraction of the incident light transmitted, k^* is a constant, and c is the concentration of absorbing material. From (3)

$$\log I/I_0 = -kc \quad (4)$$

where

$$k = k^*/2.303$$

Densitometer measurements were made of the AlCl band head occurring at 2614.5 Å. in exposures 13, 15, 16, 17 and 18 of Plate A. These exposures were all made at approximately constant pressure, 700 mm., and at various temperatures from 1000–1075°. The values of kc calculated for each exposure from the densitometer measurements are given in column 2 of Table I. It should be noted that, since the same band was measured in each exposure, the k 's are identical and only the c 's change. The k for the 2614.5 band is designated k_1 to distinguish it from the k 's for other bands.

A plot of the $\log k_1c$ values vs. $1/T$ for exposures 13, 15–18 of Plate A is shown as the circles on Fig. 3. The slope of an imaginary straight line drawn through them corresponds well to that of the solid line, which is a plot of the theoretical

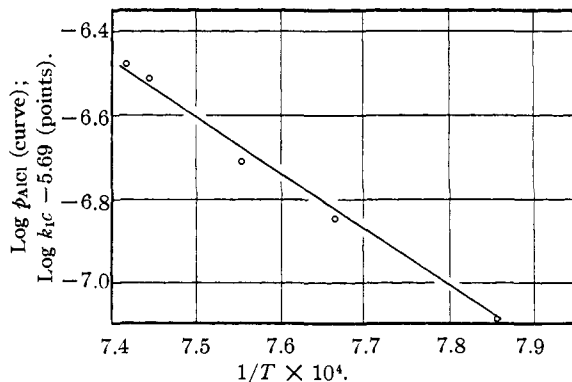

Fig. 3.—Comparison of experimental and theoretical AlCl concentrations.

(14) See L. M. Foster, THIS JOURNAL, 72, 1902 (1950).

TABLE I
 ALUMINUM MONOCHLORIDE BAND INTENSITIES

Exp. no.	$\lambda = 2614.5$		$\lambda = 2617.0$			$\lambda = 2620.0$			$\lambda = 2623.5$			$\lambda = 2622.5$		
	I/I_0	k_{1c}	I/I_0	k_{2c}	k_2/k_1	I/I_0	k_{3c}	k_3/k_1	I/I_0	k_{4c}	k_4/k_3	I/I_0	k_{5c}	k_5/k_4
A-13	0.91	0.041	0.94	0.026	0.63									
A-14	.91	.041	.94	.026	.63									
A-15	.85	.070	.91	.041	.58	0.97	0.013	0.19						
A-16	.80	.096	.88	.055	.57	.95	.022	.23						
A-17	.68	.167	.79	.102	.61	.93	.031	.19						
A-18	.70	.154	.80	.096	.62	.93	.031	.20						
A-19	.68	.167	.78	.108	.64	.92	.036	.22						
A-20	.67	.174	.79	.102	.58	.93	.031	.18						
A-21	.62	.208	.74	.130	.62	.94	.026	.12						
A-22	.49	.310	.66	.180	.58	.88	.055	.18						
B-2						.94	.028							
B-3						.16	.796		0.64	0.284	0.35	0.52	0.194	0.68
C-8						.19	.722		.55	.260	.36	.59	.229	.88
C-19									.16	.796		.23	.638	.80
C-20												.17	.769	
Average					.61			.19			.36			.79
Exp. no.	$\lambda = 2627.2$			$\lambda = 2639.3$			$\lambda = 2647.5$			$\lambda = 2664.1$				
	I/I_0	k_{6c}	k_6/k_5	I/I_0	k_{7c}	k_7/k_6	I/I_0	k_{8c}	k_8/k_7	I/I_0	k_{9c}	k_9/k_8		
B-4				0.66	0.180		0.82	0.086	0.48					
B-5				.38	.420		.64	.194	.46					
B-7				.15	.824		.35	.456	.55					
B-8							.11	.958		0.57	0.244	0.25		
B-10										.26	.585			
B-12										.13	.886			
B-13										.14	.854			
B-14										.31	.508			
B-15										.39	.409			
C-8	0.80	0.096	0.42											
C-9				.27	.568		.53	.276	.49					
C-10				.22	.657		.46	.337	.51					
C-11				.24	.620		.51	.301	.49					
C-13				.18	.745		.40	.398	.53	.81	.089	.22		
C-14							.21	.677		.75	.125	.19		
C-15							.21	.677		.73	.138	.20		
C-16							.24	.620		.72	.142	.23		
C-18				.11	.958		.35	.456	.48	.80	.092	.21		
C-19	.51	.292	.46	.74	.130	0.44	.91	.041	.32					
C-20	.39	.408	.53	.65	.186	.45	.85	.070	.38					
C-21	.29	.537		.58	.236	.44	.84	.076	.32					
C-23							.31	.508		.79	.102	.20		
C-24							.22	.657		.73	.136	.25		
Average			.47			.45			.47			.22		

AlCl concentrations calculated from Table III (Appendix). This shows that the temperature dependence of the AlCl concentration, which was assumed for the calculations, is correct. In order to assign the absolute values of AlCl concentration to the exposures of Plate A it was necessary to adjust the ordinate of the experimental points to best fit the theoretical curve.

The equation for the best line through the experimental points was

$$\log k_{1c} = -1.35 \times 10^4/T + 9.21 \quad (5)$$

Comparing this with (24) of the appendix

$$\log p_{\text{AlCl}} = \log k_{1c} - 5.69 \quad (6)$$

whence, if c is expressed in the same units as p_{AlCl} (atmospheres)

$$\log k_1 = 5.69$$

and

$$k_1 = 4.9 \times 10^5 \quad (7)$$

Substituting this k_1 into the values of k_{1c} in Table I, the AlCl concentrations are obtained. These are given in the last column of Table II. Knowing k_1 and the concentration for a particular exposure, the k 's are calculated for the other bands appearing in the same exposure from their measured density ratios, I/I_0 . Using these new k 's, it is possible to determine the AlCl concen-

tration in any exposure where a band, whose k is known, appears. In this manner the AlCl concentrations were determined for all of the exposures of interest on Plates B and C. These are compared with the theoretical concentrations in Table II.

TABLE II
EXPOSURE DATA AND COMPARISON OF CALCULATED AND OBSERVED AlCl CONCENTRATIONS

Exp. no.	Temp., °C.	p_{AlCl_3} atm.	p_{AlCl} in atm. $\times 10^8$ obs.	p_{AlCl} in atm. $\times 10^8$ calcd.
$\text{AlCl}_3 \longrightarrow \text{AlCl} + \text{Cl}_2$				
A-13	1000	0.92		0.0084
A-15	1030	.90		.014
A-16	1050	.92		.020
A-17	1075	.92		.034
A-18	1070	.92		.031
$\text{AlCl}_3 + 2\text{Al} \longrightarrow 3\text{AlCl}$				
B-2	396	0.12	0.030	0.39
B-3	500	.12	0.81	9.3
B-4	600	.12	3.3	93
B-5	648	.12	7.6	240
B-7	700	.12	17	590
B-8	750	.12	40	1000
B-10	848	.12	100	3700
B-12	902	.12	160	5400
C-8	675	1×10^{-7}	0.78	
C-9	675	1.1×10^{-2}	11	320
C-10	698	2.5×10^{-2}	13	420
C-11	700	0.9×10^{-2}	12	300
C-13	698	5.1×10^{-2}	15	540
C-14	702	0.12	24	710
C-15	706	.24	25	870
C-16	705	.37	25	950

The other entries in Table I are self-explanatory with the possible exception of the extinction coefficient ratios, k_2/k_1 , etc. The fact that these ratios are approximately constant indicates that the change in relative intensity of different absorption bands with temperature is not greater than the deviations due to other causes so does not invalidate the conclusions.

Discussion

In view of the general agreement between experiment and theory there is little question that the reaction involved in the catalytic distillation of aluminum with aluminum chloride is expressed correctly by relation (2).

Except for the anomalous behavior found in some experiments at high aluminum chloride pressures, the aluminum monochloride concentrations found experimentally agree within a factor of 10-30 with those calculated from published thermodynamic data. These data are subject to some question. The heat of vaporization of aluminum was based on a boiling point of 2330°K., which is an average of two widely separated values. The spectroscopically determined heat of dissociation of AlCl is also subject

to considerable error. The errors in the various quantities partly cancel because of the similarity between the two reactions compared.

Assuming the validity of the literature data, the ten to forty-fold disagreement between the measured and calculated AlCl concentrations could easily result from non-equilibrium conditions in the system. The greatest discrepancy occurred at the highest AlCl concentrations where equilibrium is least apt to be obtained.

The very great effect which metallic aluminum exerts on the AlCl concentration was clearly brought out in the investigation. Under comparable conditions of temperature and aluminum trichloride pressure (1000° and 0.12 atm.) 0.003×10^{-5} atm. AlCl pressure was found, by extrapolation, due to the thermal dissociation of aluminum trichloride; whereas 340×10^{-5} atm. was found when metallic aluminum was added—a more than one hundred thousandfold increase.

The prediction and finding of unstable AlCl at low temperatures (400°) was a surprising result of the investigation.

Acknowledgment.—The authors wish to thank Mr. E. L. McMahan of the spectrographic laboratory for his assistance in the spectroscopic work.

Appendix

Calculation of the Equilibrium Constants and the AlCl Concentrations.—To evaluate the equilibrium constants, and hence the AlCl concentrations, for the reactions

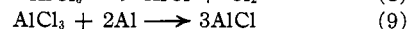
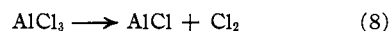

the free energy content of AlCl was computed and values for aluminum chloride, aluminum and chlorine were selected from the literature. The free energy function, $-(F_0 - E_0^0)/(T)$, for AlCl was calculated (omitting effects arising from nuclear spin and isotopic composition) by the Sakur-Tetrode equation¹⁵ and the method of Gordon and Barnes¹⁶ for evaluating the partition function for $^1\Sigma$ molecules.

The constants necessary for calculating the free energy function of AlCl, as determined from analysis of its band spectrum, are given in Herzberg¹⁷ as: $\omega_e = 481.3$, $\omega_e x_e = 1.95$, $B_e = 0.242$ and $\alpha_e = 0.002$, with all values in cm^{-1} .

The energy content of AlCl at 0°K., $E_{0\text{AlCl}}^0$, was obtained from the sum of the ΔE_0^0 's of three reactions

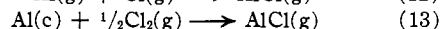
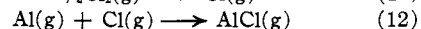
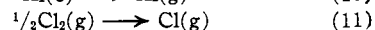
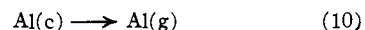

(15) H. S. Taylor and S. Glasstone, "Treatise on Physical Chemistry," Vol. I, Van Nostrand, New York, N. Y., 1942, Chap. 4.

(16) A. R. Gordon and C. Barnes, *J. Chem. Phys.*, **1**, 297 (1933).

(17) G. Herzberg, "Molecular Spectra and Molecular Structure, Vol. I, Diatomic Molecules," Prentice-Hall, New York, N. Y., 1939, p. 482.

For (10) we employed Kelley's¹⁸ value of $\Delta E_0^0 = 66.9$ kcal. per mole, based on a boiling point of 2330°K. Herzberg¹⁷ gives the energy of dissociation, D_0 , of Cl_2 as 2.481 e-volts (57.2 kcal.), and that of AlCl as 4.72 e-volts (108.8 kcal.). Using these values, $E_{0\text{AlCl}}^0 = -13.3$ kcal.¹⁹

Giauque and Overstreet²⁰ have calculated the free energy of $\text{Cl}_2(\text{g})$. The free energy values for $\text{Al}(\text{c})$ were taken from Kelley.¹⁸

Treadwell and Terebesi²¹ determined the free energy of formation of $\text{Al}_2\text{Cl}_6(\text{g})$ by e. m. f. measurements. Their relations, converted to the units employed here, are

$$-\frac{\Delta F^0}{T} = \frac{305,200}{T} - 63.2 \text{ (to } 930^\circ\text{K.)} \quad (14)$$

$$-\frac{\Delta F^0}{T} = \frac{311,200}{T} - 67.2 \text{ (930-1500}^\circ\text{K.)} \quad (15)$$

From Smits and Meijering's²² measurements of the change of the equilibrium constant with temperature for the reaction

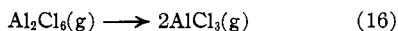

the free energy change of the dissociation is

$$-\frac{\Delta F^0}{T} = -\frac{28,200}{T} + 32.8 \quad (17)$$

Combining (17) with (14) and (15), the free energy of formation of one mole of $\text{AlCl}_3(\text{g})$ is

$$-\frac{\Delta F^0}{T} = \frac{138,500}{T} - 15.2 \text{ (to } 930^\circ\text{K.)} \quad (18)$$

$$-\frac{\Delta F^0}{T} = \frac{141,500}{T} - 17.2 \text{ (930-1500}^\circ\text{K.)} \quad (19)$$

The free energy content of AlCl_3 is then given by the relation

$$\frac{F_{\text{AlCl}_3(\text{g})}^0}{T} = \frac{\Delta F_{\text{AlCl}_3(\text{g})}^0}{T} + \frac{F_{\text{Al}(\text{c})}^0}{T} + \frac{3}{2} \frac{F_{\text{Cl}_2(\text{g})}^0}{T} \quad (20)$$

We now have all the information necessary to determine the free energy change and hence the equilibrium constants for reactions (8) and (9). The necessary functions and final results

(18) K. K. Kelley, U. S. Bur. Mines Bulletin No. 383 (1935).

(19) Kelley's boiling point of aluminum was the average of 2073°K. and 2473°K. There is reason to think that the true boiling point is closer to the higher value. Had we chosen this, E_0^0 for monochloride would be -11.0 kcal. and better agreement between observed and calculated AlCl concentrations would result. However, there still remained the uncertainty in D_0 for AlCl . Herzberg gives this as equal to, or less than, 4.72 e-volts (we used 4.72). A. G. Gaydon, "Dissociation Energies and Spectra of Diatomic Molecules," John Wiley, New York, (1947), however, chose 3.1 e-volts, while E. Miescher, *Helv. Phys. Acta*, **9**, 693-705 (1936), used 5.3 e-volts. After our calculations were made, P. Gross, C. S. Campbell, P. J. C. Kent and D. L. Levi. *Discussions Faraday Soc.*, No. **4**, 206-215 (1948), published an experimental value of -11.5 kcal. for ΔH_{298}^0 of AlCl (which for this case is essentially E_0^0) which would seem to justify an alteration of the literature values we chose for D_0 or the aluminum boiling point. The agreement with our value was close enough, however, that recalculation of the data, using a new constant, seemed unwarranted.

(20) W. F. Giauque and R. Overstreet, *THIS JOURNAL*, **54**, 1731 (1932).

(21) W. D. Treadwell and L. Terebesi, *Helv. Chim. Acta*, **18**, 103 (1935).

(22) A. Smits and J. L. Meijering, *Z. physik. Chem.*, **B41**, 98 (1938).

are tabulated in Table III for various temperatures.

TABLE III (APPENDIX)

THERMODYNAMIC FUNCTIONS AND EQUILIBRIUM CONSTANTS

Temp., °K.	$-\frac{(F_0^0 - E_0^0)}{T}$						log K_1	log K_2
	for AlCl (g)	for AlCl ₃ (g)	for Al (c)	for Cl ₂ (g)	for AlCl ₃ (g)	for AlCl (g)		
298	46.99	444.8	3.1	45.9	521.8	91.6	-84.0	-55.3
500	50.98	261.8	5.3	49.9	341.9	77.6	-46.8	-26.2
700	53.62	182.5	6.9	52.5	268.2	72.6	-31.3	-14.0
1000	56.60	124.5	9.1	55.5	216.8	69.9	-20.0	-5.5
1100	57.42	111.6	9.9	56.3	205.9	69.5	-17.5	-3.8
1200	58.17	100.8	10.6	57.0	196.9	69.2	-15.5	-2.3
1300	58.80	91.8	11.3	57.7	189.5	69.0	-13.7	-1.1
1400	59.51	84.0	11.9	58.3	183.3	69.0	-12.3	0.0
1500	60.01	77.2	12.4	58.9	177.9	68.9	-11.0	0.9
1700	61.16	66.1	13.4	60.0	169.4	69.0	-8.7	2.4
2000	62.52	53.6	14.6	61.4	160.2	69.2	-6.5	3.9
2400	64.07	41.9	16.0	63.0	152.4	69.6	-4.3	5.3

The equilibrium constant, K_1 , for reaction (8) is

$$K_1 = (p_{\text{Cl}_2})(p_{\text{AlCl}})/p_{\text{AlCl}_3} \quad (21)$$

In the case where all of the chlorine and aluminum monochloride come from dissociation of aluminum trichloride originally present, $p_{\text{Cl}_2} = p_{\text{AlCl}}$ and (21) becomes

$$K_1 = p_{\text{AlCl}}^2/p_{\text{AlCl}_3} = \alpha^2 P/(1 - \alpha) \quad (22)$$

where α is the fraction of AlCl_3 reacted and P is the initial aluminum trichloride pressure. For reaction (9), the equilibrium constant K_2 is

$$K_2 = p_{\text{AlCl}}^3/p_{\text{AlCl}_3} = 27\alpha^3 P^2/(1 - \alpha) \quad (23)$$

The equilibrium AlCl pressures calculated from (22) and (23), employing the calculations of Table III, are given in Table II (text) as a function of temperature and initial aluminum trichloride pressure.

The solid line of Fig. 3 (text) is a plot of the calculated AlCl pressure as a function of temperature at one atmosphere AlCl_3 pressure, for the thermal dissociation of AlCl_3 (reaction 8). The line is essentially straight and can be represented by the equation

$$\log p_{\text{AlCl}} = \frac{-1.35 \times 10^4}{T} + 3.52 \quad (24)$$

This is the relation (referred to on page 2583 of the text) used to relate the absorption intensity of the exposures of Plot A to absolute AlCl concentrations.

Summary

The reaction between aluminum trichloride and metallic aluminum has been investigated spectroscopically. Unstable aluminum monochloride, AlCl , is a product of the reaction.

The monochloride concentration was measured experimentally and general agreement was found with that calculated for the reaction $\text{AlCl}_3 + 2\text{Al} \rightarrow \text{AlCl}$ from published thermodynamic data.

Under the same experimental conditions, an

increase in AlCl concentration of over one hundred thousandfold was noted, when aluminum was added to aluminum trichloride, over that

observed by thermal dissociation of aluminum trichloride alone.

NEW KENSINGTON, PA. RECEIVED OCTOBER 13, 1949

[CONTRIBUTION FROM THE LABORATORIES OF THE SLOAN-KETTERING INSTITUTE FOR CANCER RESEARCH]

The Ultraviolet Absorption Spectra of Pyrimidines and Purines¹

BY LIEBE F. CAVALIERI AND AARON BENDICH

In a previous communication² evidence was presented which indicates that the ultraviolet absorption spectra of pyrimidines and purines is due mainly to the —C=C—C=N— or —C=C—C=O chromophore of the pyrimidine ring. We have

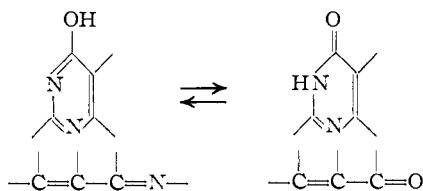

continued the investigation with the aim of gaining more knowledge concerning the effect of substituents on the spectra of these compounds.

Results

2,6- and 4,6-disubstituted and 2,4,6-trisubstituted pyrimidines exhibit a maximum in the region of $264 \pm 6 \text{ m}\mu$ (Fig. 1); the 2,4,6-trisubstituted-5-formamidopyrimidines possess a band at $265 \pm 6 \text{ m}\mu$. In a homogeneous series, the molecular extinction coefficients decrease in the order: 2,4,6-trisubstituted > 2,4,6-trisubstituted-5-formamido > 4,6-disubstituted > 2,6-disubstituted. In both the 2,6- and 4,6-disubstituted pyrimidines an hydroxyl substituent results in a higher extinction than an amino substituent. In the trisubstituted series, 4,6-diamino-2-hydroxypyrimidine represents an exception since its molecular extinction is higher than that of 2,4,6-trihydroxypyrimidine. In all series an hydroxyl group in position 2 results in higher extinction values than an hydroxyl group in position 6.

Discussion

Additional corroborative evidence which supports the postulate that the —C=C—C=O system is a major chromophore is found in the spectra of 4,5-dihydrouracil (I) and thymine glycol (II). Whereas uracil (III) and thymine (IV) possess intense maxima at $260 \text{ m}\mu$ ($\epsilon = 9000$) and 262

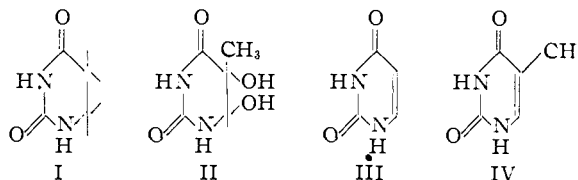

$\text{m}\mu$ ($\epsilon = 8600$),³ dihydrouracil (I)^{4,5} and thymine glycol (II) do not absorb in this region. Since a

—C=C—C=O grouping in I and II cannot exist by virtue of the fact that the —C=C— at the 4,5-position has been saturated, it is apparent that

the —C=C—C=O system is a necessary feature for the absorption of light in this region. The

—C=N— in the 2,3-position may be involved in the chromophoric system but previous² evidence indicates that an intense maximum in this region can occur when this double bond has been removed from the molecule. A clue as to the extent of contribution from the 2,3-double bond may be found by examining the chemical behavior of pyrimidines.

There is a considerable quantity of evidence which strongly suggests that the pyrimidine (and purine) nucleus possesses a rather low degree of aromaticity. Thus the action of nitrous acid on certain aminopyrimidines and aminopurines produces hydroxy derivatives rather than the diazonium salts commonly encountered with aromatic structures⁶; in some cases no reaction occurs. The reactions of halogens are atypical of aromatic compounds. Treatment of uracil with bromine leads to 5,5-dibromo-4-hydroxyhydrouracil. On heating, this compound is converted to 5-bromouracil and this bromine atom is easily hydrolyzed to an hydroxyl group.⁶ In some instances nitration leads to 5-nitro derivatives, while in others addition of nitric acid across the 4,5-double bond occurs. There appears to be no record of sulfonation reactions. In general the pyrimidine ring is destroyed by the action of alkali; in some

(3) Heyroth and Loofbourow, *ibid.*, **56**, 1728 (1934); Baudisch and Davidson, *J. Biol. Chem.*, **64**, 233 (1925).

(4) A weak band ($\lambda = 258 \text{ m}\mu$, $\epsilon = 700$) for I has been reported, Austin, *THIS JOURNAL*, **56**, 2141 (1934). In our hands a carefully purified sample showed no maximum.

(5) Fischer and Roeder, *Ber.*, **34**, 3751 (1901).

(6) Levene and Bass, "Nucleic Acids," Reinhold Publ. Corp., New York, N. Y., 1931.

(1) This work was supported by grants from the Office of Naval Research, United States Navy, the James Foundation of New York, Inc., the National Cancer Institute of the United States Public Health Service.

(2) Cavalieri, Bendich, Tinker and Brown, *THIS JOURNAL*, **70**, 3875 (1948).